

HydroLink® Battery Watering Kit



The HydroLink Battery Watering kit is designed exclusively for specific Trojan® brand wet/lead-acid batteries supplied by Tennant (See battery list below). This kit allows for a safer, quicker and easier way to maintain the proper electrolyte levels in your batteries. Kit 9010300 contains the parts needed for 24V battery models, and kit 9010301 contains the parts needed for 36V battery models. Carefully follow the Installation and Operation Instructions below:

NOTE: DO NOT DISCARD this Instruction Bulletin. Keep for future reference to order replacement parts.

INSTALLATION INSTRUCTIONS:

Installation Time: 1 hour

Special Tools Required: None

Personal Protection Equipment Required:
Rubber Gloves and Safety Goggles.

PROTECT THE ENVIRONMENT: Please dispose of packaging materials and used machine parts such as batteries in a safe environmentally way according to your local waste disposal regulations.

1. Park the machine on a level surface, turn off machine and remove the key.
2. Disconnect the the main battery cable connection from machine.
3. Remove and discard all battery caps from batteries (Figure 1).

FOR SAFETY: When servicing batteries, wear protective gloves and eye protection. Avoid contact with battery acid.

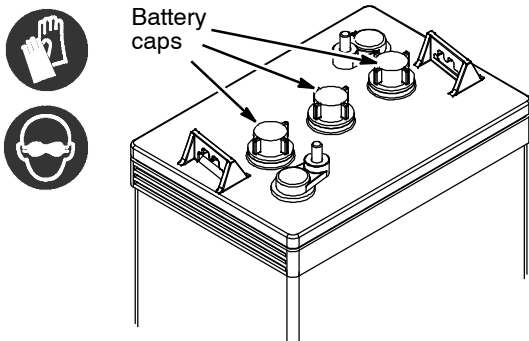

Fig. 1

4. Install battery fill caps on batteries (Figure 2). Firmly press caps into place, do not use hammer. Ensure caps are completely seated to avoid spillage.

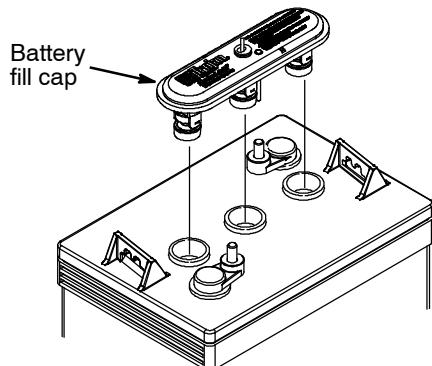

Fig. 2

Kit Contents		
Part No.	Description	Qty.
1204142	Battery Fill Cap [24V Kit 9010300]	4
1204142	Battery Fill Cap [36V Kit 9010301]	6
1204143	Yellow Fill Cap Float (Replacement part 12/pk)	
1070394	Battery Water Tube Manifold [24V Kit 9010300]	1
1201997	Battery Water Tube Manifold [36V Kit 9010301]	1
1058939	Hand Pump Hose	1
1071084	Tag, Operator Instructions	1
130773	Cable Tie, Nyl	2

Battery Watering Kit designed for following batteries:

Battery	Part No.	Trojan Battery Type*
12 VDC 155 AH	1015046	T-1275
12 VDC 225 AH	1070591	J185HGAC
6 VDC 220 AH	10155	T105
6 VDC 244 AH	390825	T-145
6 VDC 240 AH	222280	T125
6 VDC 360 AH	1070587	J305HGAC
6 VDC 435 AH	1204146	L16HGAC

* Trojan battery type located on battery label.

5. Remove vent plug in each battery fill cap. Snap the battery water tube manifold into each battery fill cap as shown (Figure 3). Press firmly until you hear a click.

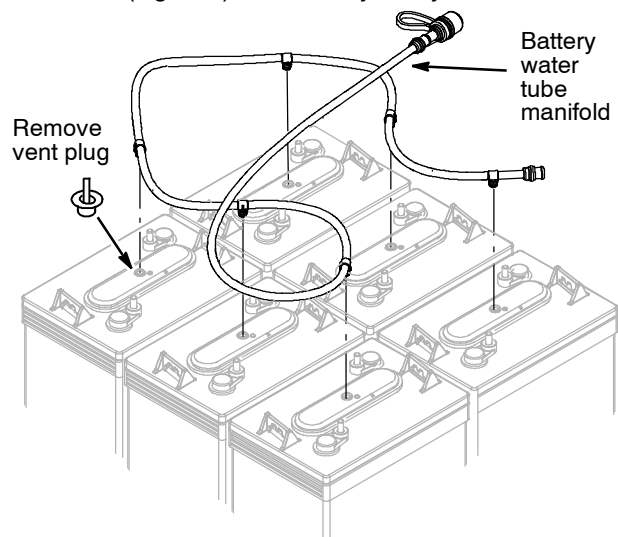

Fig. 3

HydroLink® Battery Watering Kit

6. Attach the Operating Instructions tag to the end of battery water tube with two cable ties as shown (Figure 4).

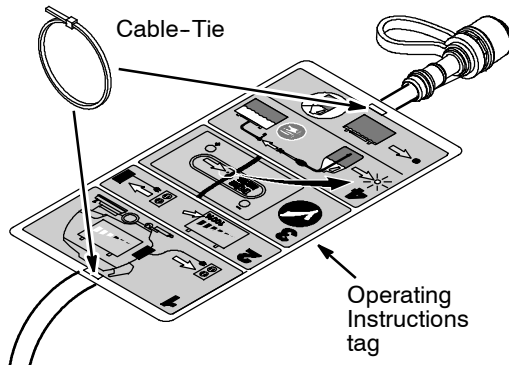

Fig. 4

7. Before using battery watering kit, make sure all connections are secure and leak free.

OPERATING INSTRUCTIONS:

1. Fully charge batteries prior to using the battery watering kit (Figure 5). Refer to the Machine's Operator Manual for charging instructions.

IMPORTANT: Do not add water to batteries before charging, the electrolyte level will expand and may overflow when charging.

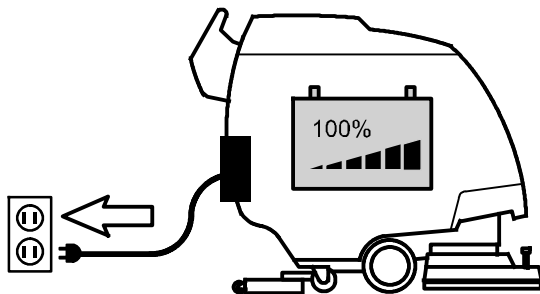
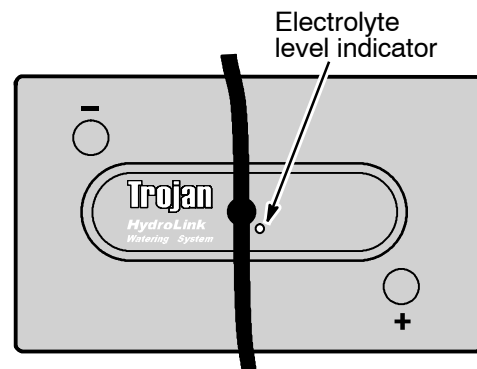

Fig. 5

2. After charging batteries, check the electrolyte level indicator located on each battery cap (Figure 6). If any of the level indicators are WHITE watering is required. If any of the level indicators are BLACK watering is not required (Figure 6).

NOTE: If you have a mixture of white and black indicators, proceed to add water. The fill cap float will prevent adding too much water.

FOR SAFETY: When servicing batteries, wear protective gloves and eye protection. Avoid contact with battery acid.



Add Distilled Water



Electrolyte level is correct

Fig. 6

3. To add water to batteries, remove the dust cap from the battery water tube manifold and connect the hand pump hose (Figure 7).

Submerge the other end of the hand pump hose into a bottle of distilled water. Squeeze the bulb until firm. The level indicators will turn black when electrolyte is at the correct level.

Hand pump hose

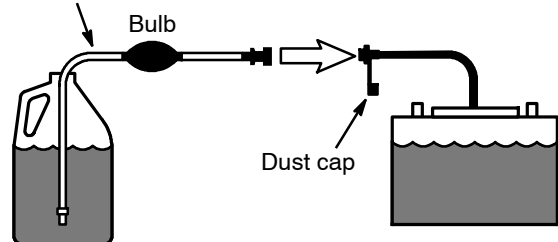

Distilled water

Fig. 7

4. After adding water, replace dust cap and store the hand pump hose inside the machine's battery compartment for future use.
5. Check the electrolyte level on a weekly basis.
6. Inspect the condition of the battery watering kit on a quarterly basis. Make sure it is in good working condition and all connections are secure and leak free.